

# **gPod Accessible Blood Glucose Meter**

Week 1

January 22, 2006

David Price

## **Work Completed**

During winter break I researched details relating to the LCD screen and microprocessor. I obtained many application notes relating to the controlling of a serial LCD display using a PIC16 microprocessor. I also found an appropriate memory module to be used for storage of measurement data and as a frame buffer for the LCD.

During the first week of classes parts orders were received and checked. An ordering mistake was found with our LCD screen choice and a second module needed to be ordered. The screen ordered was a smaller size of the version we originally intended to use. In addition to a new LCD screen, we placed an order for a development board to accompany the LCD screen. The development board is an economical way to connect the screen and interface it with either a PC or the microprocessor. It will allow me to get a comprehensive understanding of the hardware and software aspects of the display without worrying about incorrectly connecting the display and damaging it. In the long-run I feel that the development board will simplify interfacing the LCD to the microprocessor and will provide a safe testing environment.

In addition to the mistake with the LCD troubles were encountered when soldering the speech chip to the DIP adapter. Both were damaged beyond repair and needed to be reordered. The soldering irons in the lab make soldering 0.8 mm spacing a challenge. Future soldering may take place at my place of work back in Massachusetts to eliminate any further damage.

Great progress was made in the area of glucose detection and measurement. Matt and I spent Wednesday trying to piggyback measurements from the OneTouch Ultra meter. Measurements with an oscilloscope or multimeter caused the OneTouch Ultra to enter an error state and not acquire a reading. We decided to eliminate this problem by constructing our own glucose measurement circuit and taking readings from an oscilloscope. Figure 1 shows the schematic of the test setup. A potential of 400 mV was applied between the Reference Electrode and Working 2 and Working 1. A sample glucose solution of ~114 mg/dL was applied to the test strip connected to the three electrodes. The voltage level was read using a scope and Figure 2 shows the results. Channel 1 (orange) shows the data from Working 1 and Channel 2 (blue) shows Working 2. The data in Figure 2 appears almost exactly as expected from the research from last semester. One difference in our data is it is inverted producing a positive sloping line instead of a negative sloping one. More data analysis and filtering was completed using LabView.

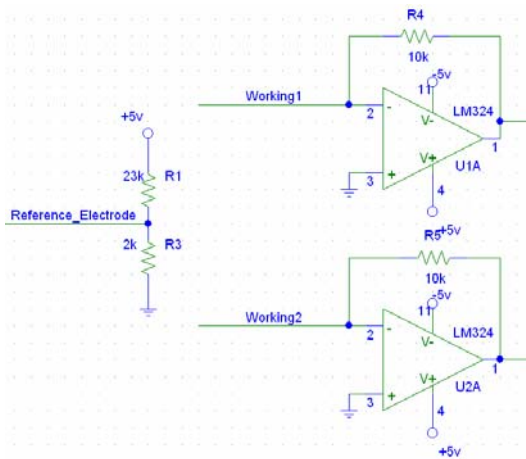

**Figure 1 Glucose Circuit**

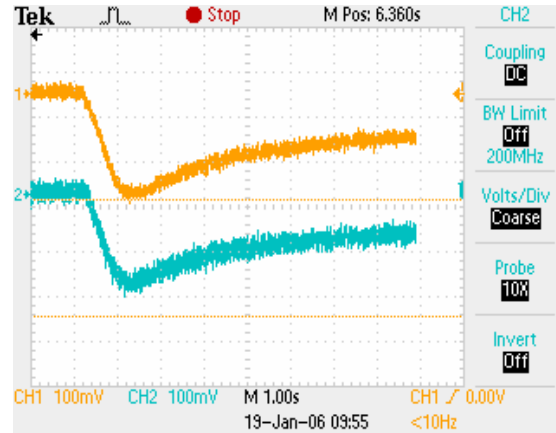

**Figure 2 Measurement Results**

## Future Work

More work this week will be done on the glucose measurements and the source of inversion of the data. We will rework the circuit to produce a waveform in the positive voltage range to accommodate the A/D converters on the microprocessor. We will also work to correlate the voltage/current to glucose concentration by running a series of tests with different levels of glucose. Once this curve is obtained we can then start work on capturing the data with the microprocessor and working with the A/D converters.

Further work is dependent on the arrival of more components ordered during Week 1. If the new speech chip and adapters arrive during the week we will attempt to carefully solder the chip to the adapter and start prototyping and testing the speech chip circuits. Additionally if the LCD development board arrives (pending purchase approval) work will be started on creating the user interface.

## Project Review

The project is progressing in a positive manner. The delay in the work on the LCD and speech chip was offset by the tremendous progress made in the glucose measurement portion of the project. The glucose measurement segment of the project is nearly two weeks ahead of schedule. The speech chip and LCD portions of the project will be back on track as soon as the new parts are received. By the end of the week we hope to have an accurate glucose curve and start writing code to obtain the data using the microcontroller. The project is also staying well under budget. Total costs to date are \$342.24. Additional orders from Week 1 place the projected costs at \$500. After this week no major purchases are scheduled until board layout and assembly occurs.

## Hours Worked

Hours spent on the project for Week 1 : 15